



1000Kg Electric Chain Hoist

Lifting capacity: 1000Kg

Lifting height: 1-50m, higher lifting height can be customized.

Power supply: 220-550V 50/60Hz 1/3 phase.



Products Code

WBH / HHBB - 010 01 S E

Products Series

Lifting Capacity	
Code	Load(t)
001	0.1
002	0.2
003	0.3
004	0.4
005	0.5
010	1.0
015	1.5
020	2.0
025	2.5
030	3.0
050	5.0
075	7.5
100	10
150	15
200	20
300	30
350	35

Falls	
Code	Falls
01	1
02	2
03	3
04	4
06	6
08	8
10	10
12	12
16	16

Speed Type
 S. Single Speed
 D. Dual Speed

Hoist Type
 F. Hook type
 M. Manual trolley type
 E. Motorized trolley type
 L. Low headroom type

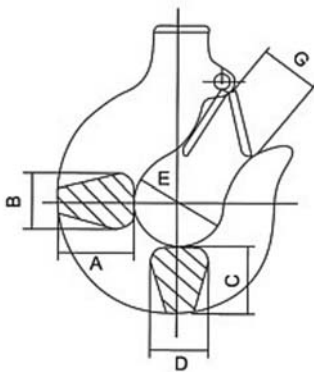

Type	Load(t)	T	B	A	B	C	D	E	G
WBH / HHBB	0.2, 0.3, 0.5	T	B	27	18	25	17	35	28
	1	T	B	34	24	30	24	42	32
	2	T	B	46	29	39	30	49	40
	3	T	B	56	35	49	34	59	48
	5	T	B	67	43	57	44	60	48
	7.5	T	B	82	55	80	48	85	80
	10	T	B	82	55	80	48	85	80
	15	T	B	110	78	120	80	120	96
	20, 25	T	B	142	95	155	98	150	115
	30	T	B	160	130	150	130	140	95
	35	T	B	195	150	160	150	160	110

T-top hook / B-load hook

1000Kg Electric Chain Hoist

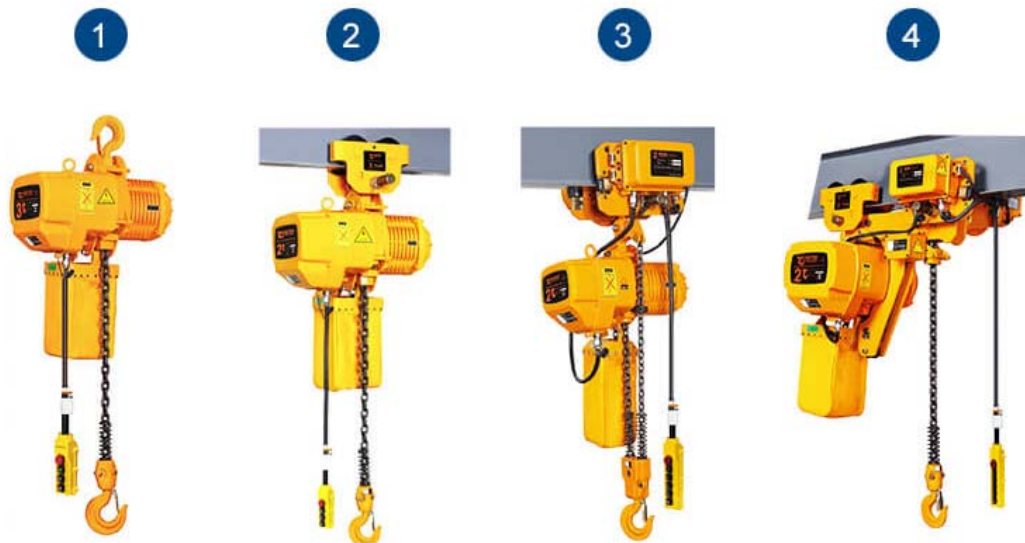

Type	Lifting Speed (m/min)	Lifting Motor			Chain Falls	Chain Spec	Weight (Kg)	Weight Added with 1m Higher
		Power	Rotation Speed (r/min)	Power Supply				
① Hook type Electric Chain Hoist								
WBH-01001SF	6.6	1.5	1440	200-460V 1/3 Phase 50/60Hz	1	φ 7.1	61	1.1
WBH-01002SF	3.4	0.75	1440		2	φ 6.3	52	1.62
WBH-01001DF	6.9/2.3	1.8/0.6	2890/980		1	φ 7.1	61	1.1
WBH-01002DF	3.5/1.2	0.8/0.27	2890/980		2	φ 6.3	52	1.62
② Manual Trolley type Electric Chain Hoist								
WBH-01001SM	6.6	1.5	1440	200-460V 1/3 Phase 50/60Hz	1	φ 7.1	67	1.1
WBH-01002SM	3.4	0.75	1440		2	φ 6.3	67	1.1
③ Motorized Trolley type Electric Chain Hoist								
WBH-01001SE	6.6	1.5	1440	200-460V 1/3 Phase 50/60Hz	1	φ 7.1	103	1.1
WBH-01002SE	3.4	0.75	1440		2	φ 6.3	101	1.62
WBH-01001DE	6.9/2.3	1.8/0.6	2890/980		1	φ 7.1	116	1.1
WBH-01002DE	3.5/1.2	0.8/0.27	2890/980		2	φ 6.3	101	1.62
④ Low Headroom type Electric Chain Hoist								
WBH-01001SL	6.6	1.5	1440	200-460V 1/3 Phase 50/60Hz	1	φ 7.1	60-190	1.1

300Kg-5Ton

Manual Trolley

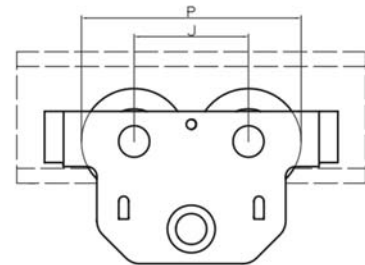
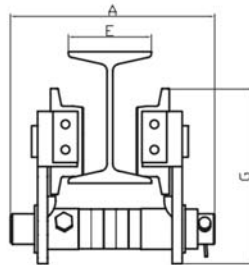

Type		MT-003	MT-005	MT-010	MT-020	MT-030	MT-050
Capacity(t)		0.3	0.5	1	2	3	5
Unit(mm)	A	460	200	200	218	275	275
	G	180	170	170	205	236	280
	J	91	115	115	138	157	178
	E	52-100	52-120	52-120	60-105	60-105	80-180
	P	163	221	221	265	305	332
Minimum Turning Radius(m)		0.6	0.6	0.6	1.0	1.0	1.2

300Kg-10Ton

Motorized Trolley

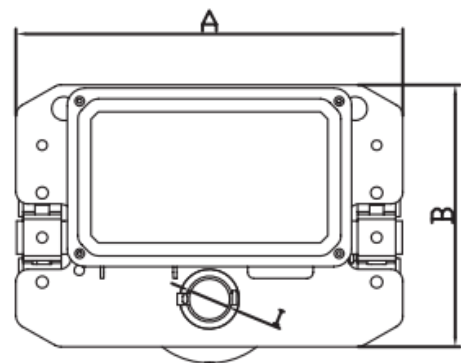
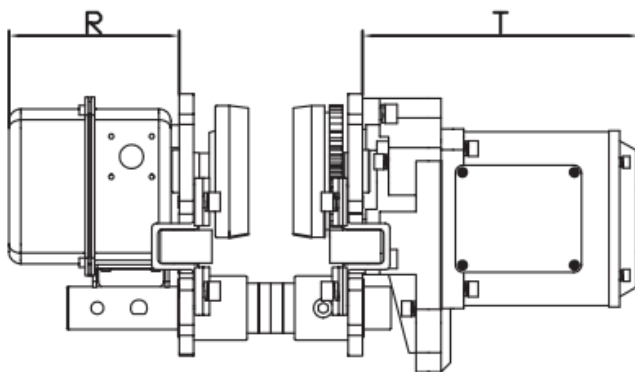

Type	ET-003	ET-005	ET-010	ET-020	ET-030	ET-050	ET-075	ET-100	
Capacity(t)	0.3	0.5	1	2	3	5	7.5	10	
Unit(mm)	A	315	315	315	325	340	400	400	500
	B	212	212	212	220	250	291	291	370
	R	120	142	142	142	142	142	142	142
	T	142	231	231	231	231	231	231	231
	I	φ 28	φ 31	φ 31	φ 36	φ 43	φ 54	φ 54	φ 70
Speed(m/min)	12.2	11/21	11/21	11/21	11/21	11/21	11/21	11/21	
Motor(Kw)	0.21	0.4	0.4	0.4	0.75	0.75	0.75	0.75	
Minimum Turning Radius(m)	0.8	0.8	0.8	0.8	1.0	1.8	1.8	2.5	
I-Beam(mm)	60-190	60-190	60-190	82-228	82-228	100-256	100-256	120-294	



Yuantai Crane Machinery

Crane&Hoist Solution Supplier

Address

3#-A-2005, Shenglong Plaza, Zhengzhou City, Henan Province, China.

Tel/Whatsapp/Wechat:

008613653868275

Fax

0086-371-65760775

Email

jason@ytcrane.com

Website

www.ythoist.com

