

Traditional Electric Hoist

YUANTAI CRANE

YT-CD₁ / MD₁ CLASSICAL MODEL

ADVANTAGE

Cost-effective and easy to use.

Components are versatile.

Optional manual trolley and electric trolley with different speeds.

The motor adopts conical rotor motor, which integrates power and braking force.

With overload, overcurrent, voltage loss, phase failure protection functions.

The power supply has a wide range of applications and adopts 36V safety voltage control to make the operation safer.

Brake material free of harmful ingredients such as asbestos, making the product more environmentally friendly.



YT-CD₁ / MD₁ Model Electric Hoist



Overview

The new CD₁ / MD₁ electric hoist is M4 working level, which completely replaces the original CD₁/MD₁ electric hoist. The product has longer durability and longer service life. It has the characteristics of compact structure, light weight, small size and convenient operation. It can be installed on the overhead I-beam alone, also it can be installed on electric or manual single-beam crane, double-beam crane, jib crane, gantry crane and other cranes.

Application

The new CD₁/MD₁ electric hoists are widely used in factories, mines, docks, warehouses, freight yards and other working environments, where the temperature is -20~+40°C and the relative humidity is not greater than 85%. It is forbidden to use in places with explosion risk filled with sulfuric acid or other corrosive gases, and places where molten metal, toxic substances, and flammable substances are lifted and transported to ensure safety (for the above special use environments, please choose other corresponding models of our company). Protective devices are required when used in severe dust or open-air places.

YT-CD₁ / MD₁ Model Electric Hoist

Features

Higher quality paint process

Environmentally friendly new paint, using a new paint process, effectively protects the electric hoist from corrosion and prolongs the use time.

More perfect safety protection device

In addition to being equipped with a fire limiter, there is also a heavy hammer-type rising limit position limiter to control different circuit breakers. Effectively avoid the "topping" accident, making the electric hoist safer.

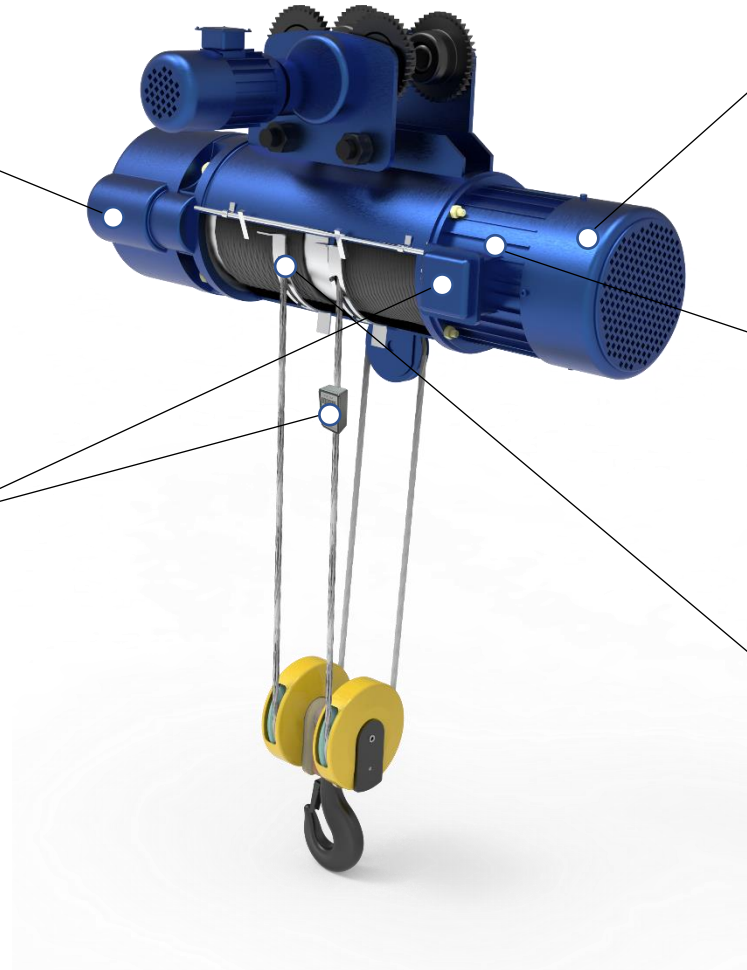

More environmentally friendly brake rings

The new brake ring is made of non-asbestos environmentally friendly materials, which will maximize the protection of the operator and the working environment.

Newly designed motor shaft

The newly designed electric hoist motor shaft adopts a unique heat treatment process, which will greatly improve the strength of the motor shaft, prolong the service life and reduce the wear rate of parts.

Effectively prolong the life of wearing parts

The material of the rope guide card plate is upgraded to Q345, which greatly prolongs the service life of wearing parts.

YT-CD₁ / MD₁ Model Electric Hoist

Supply Scope

For monorail (single girder)

Lifting capacity: 0.5-20 ton

Lifting height: 3m, 6m, 9m 12m, customized

Power supply: 220-550V 50/60Hz 3Phase



For crab hoist (double girder)

Lifting capacity: 0.5-32 ton

Lifting height: 3m, 6m, 9m 12m, customized

Power supply: 220-550V 50/60Hz 3Phase

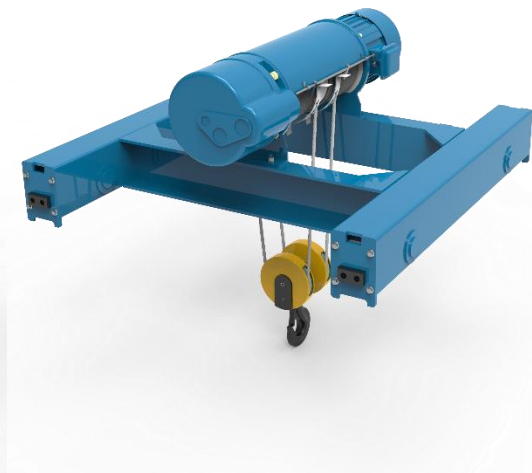
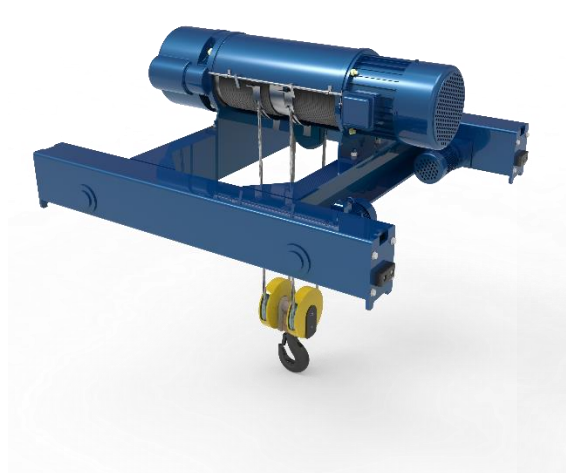

Model			CD ₁								
Capacity	Tons		0.25	0.5	1	2	3	5	10	16	20
Lifting height	M		3,6,9	6,9,12	6,9,12,18,24,30				9,12,18,24,30		
Lifting speed	M/MIN		8	8	8				7	3.5	3.5
Travelling speed	M/MIN		20	20/30	20/30	20/30	20/30	20/30	20/30	18	20
Wire rope		Dia.(mm)	3.6	4.8	7.4	11	13	15	15	17.5	19.5
		Spec.	6×39	6×37+FC	6×37+FC				6×37+FC	6×37+FC	6×37+FC
Lifting motor	Type	Type	ZD ₁ 12-4	ZD ₁ 21-4	ZD ₁ 22-4	ZD ₁ 31-4	ZD ₁ 32-4	ZD ₁ 41-4	ZD ₁ 51-4	ZD ₁ 51-4	ZD ₁ 51-4
	Power	Power(kW)	0.4	0.8	1.5	3.0	4.5	7.5	13	13	13
	Rotation speed	Rotation speed (r/min)	1380	1380	1380	1380	1380	1400	1400	1400	1400
	Current	(A)	1.25	2.2	4.3	7.6	11	18	30	30	30
Travelling motor	Type	Type	ZDY1 10-4	ZDY1 11-4	ZDY1 11-4	ZDY1 12-4	ZDY1 12-4	ZDY1 21-4	ZDY1 21-4	ZDY1 21-4	ZDY1 21-4
	Power	Power(kW)	0.06	0.2	0.2	0.4	0.4	0.8	0.8x2	0.8x2	0.8x2
	Rotation speed	Rotation speed (r/min)	1400	1380	1380	1380	1380	1380	1380	1380	1380
	Current	Current(A)	0.3	0.72	0.72	1.25	1.25	2.4	2.4	2.4	2.4
Power supply			AC 380V,50HZ,3P								

Model			MD ₁								
Capacity	Tons		0.25	0.5	1	2	3	5	10	16	20
Lifting height	M		3,6,9	6,9,12	6,9,12,18,24,30				9,12,18,24,30		
Lifting speed	M/MIN		0.8/8	0.8/8	0.8/8				0.7/7	0.35/3.5	0.35/3.5
Travelling speed	M/MIN		20	20/30	20/30	20/30	20/30	20/30	20/30	18	20
Wire rope		Dia.(mm)	3.6	4.8	7.4	11	13	15	15	17.5	19.5
		Spec.	6×39	6×37+FC	6×37+FC				6×37+FC	6×37+FC	6×37+FC
Lifting motor	Type	Type	ZDS ₁ 0.2/0.8	ZDS ₁ 0.2/1.5	ZDS ₁ 0.4/3.0	ZDS ₁ 0.4/4.5	ZDS ₁ 0.8/7.5	ZDS ₁ 1.5/13	ZDS ₁ 1.5/13	ZDS ₁ 1.5/13	ZDS ₁ 1.5/13
	Power	Power(kW)	0.4	0.2/0.8	0.2/1.5	0.4/3.0	0.4/4.5	0.8/7.5	1.5/13	1.5/13	1.5/13
	Rotation speed	Rotation speed (r/min)	1380	1380	1380	1380	1380	1400	1400	1400	1400
	Current	(A)	1.25	0.72/2.4	0.72/4.3	1.25/7.6	2.4/11	2.4/18	5.2/30	5.2/30	0.72/2.4
Travelling motor	Type	Type	ZDY ₁ 10-4	ZDY ₁ 11-4	ZDY ₁ 11-4	ZDY ₁ 12-4	ZDY ₁ 12-4	ZDY ₁ 21-4	ZDY ₁ 21-4	ZDY ₁ 21-4	ZDY ₁ 21-4
	Power	Power(kW)	0.06	0.2	0.2	0.4	0.4	0.8	0.8x2	0.8x2	0.8x2
	Rotation speed	Rotation speed (r/min)	1400	1380	1380	1380	1380	1380	1380	1380	1380
	Current	Current(A)	0.3	0.72	0.72	1.25	1.25	2.4	2.4	2.4	2.4
Power supply			AC 380V,50HZ,3P								



Yuantai Crane Machinery

Crane&Hoist Solution Supplier

Address

3#-A-2005, Shenglong Plaza, Zhengzhou City, Henan Province, China.

Tel/Whatsapp/Wechat:

008613653868275

Fax

0086-371-65760775

Email

jason@ytcrane.com

Website

www.ythoist.com