



BMS SERIES EUROPEAN ELECTRIC CHAIN HOIST



BMS系列 欧式电动环链葫芦
欧式葫芦行业标杆

HENAN YUANTAI CRANE MACHINERY



HENAN YUANTAI CRANE MACHINERY

Add: 3#-A-2005, Shenglong Plaza, Zhengzhou City, Henan Province, China.

Tel: 0086-371-65760776

Fax: 0086-371-65760775

Email: jason@ytcrane.com

Web: www.ythoist.com

Higher Performance & Faster

更高性能 / 更快速度

- ▶ BMS型欧式电动环链葫芦具有高性能、高安全性可靠性的优点，采用人性化设计理念，增加生产量，使工作达到最高效率。
- ▶ BMS european electric chain hoist with high performance,high safety reliability advantages,Using use humanized design concept to increase your productivty and make the work to achieve the highest efficiency



- ▶ **Professional chain guide design**
专业的链轮设计
- ▶ **More smooth and efficient operation**
运行更平稳高效
- ▶ **Chain wear less**
链条磨损更小

Sensitive and Fast

灵敏快捷

- ▶ BMS型欧式电动环链葫芦动作灵活，定位精准。主起升速度快速有效，低速起升确保载荷平稳，精确定位。
- ▶ BMS european electric chain hoist with flexible action,positioning accuracy. Lord stood upquickly and efficiently speed,low speed hoisting load smoothly,accurate positioning.

Longer service life for greater efficiency
满载情况下的工作寿命

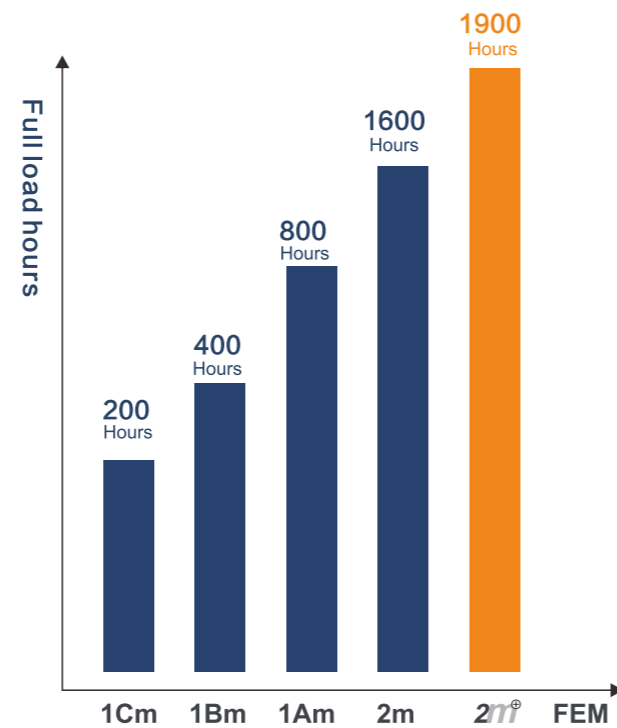

Longer service life for greater efficiency

工作效率高/使用寿命更长

- ▶ 在实际工作中，工作级别要比普通的2m工作级别多出20%，这意味着能够延长使用寿命，减少大修次数，这也是BMS型欧式电动环链葫芦所独有的特征。
- ▶ In practical terms, BMS european electric chain service life is extended by approx.20%in comparison with the conventional 2m classification for chain hoists FEM rating .This results in significantly prolonged time between service intervals and general overhauls. This extra operating life is only offered by BMS european electric chain.

Maintenance: Fast And Simple

维护快速简单



▲ Chain Guide

- ▶ BMS型欧式电动环链葫芦的所有主要驱动部件如齿轮箱，制动器和离合器等均采用特殊工艺制造，坚固耐用。BMS型系列制动器5年免维护。Yuantai 起重的产品出众的质量令其即使在繁忙工作下依然有很长的工作寿命。
- ▶ BMS european electric chain hoist,all main drive components,such as gear box,brake and clutch made by a special process,and durable,BMS series brake have 5 years free maintenance, Yuantai hoist still has a long working life with high quality even in busy work.
- ▶ 由于BMS型欧式电动环链葫芦良好的服务设计，少量必要的维护工作能够迅速简单地完成。
- ▶ Because BMS european electric chain is designed by excelent service idea and necessary maintenance work.can quickly & simply finished works.
- ▶ BMS型欧式电动环链葫芦的链轮设计紧凑、即插即用，更换快速方便，并且无需拆卸电机或齿轮箱部件。维护工作所造成的长时间停机已经成为过去。
- ▶ The chain drivce of BMS european electric chain is designed as a compact unit which is slid into place and can be replaced in a minimum of time without the need to disassemble motor or gearbox parts.Long downtimes as a result of maintenance work are now a thing of the past.

Tailored Solutions

量身定制的解决方案

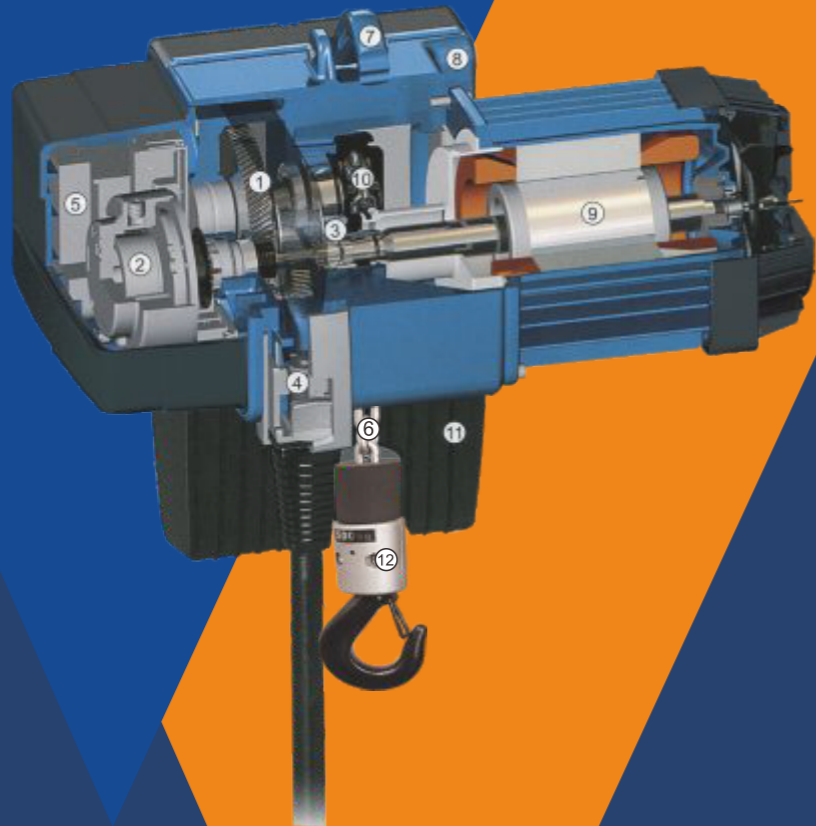

► BMS型欧式电动环链葫芦通过相关权威认证葫芦电机、环链电动葫芦以及行走电机装置的防护等级为IP55，手电门防护等级为IP65外壳，可以防潮防尘。

► BMS european electric chain hoist has been certified by the relevant national authority Protection class of hoist motor, electric chain hoist and traveling motor device are all IP55, push button control is with excellent moistureproof dustproof, IP65.

1

齿轮箱——免维护，工作级别为M6，BMS型欧式电动环链葫芦满载运行的时间长达1900小时，此为远泰的标准额定使用时间，这意味着在实际应用中远泰要多出约20%的工作寿命。齿轮箱的斜齿轮传动降低工作噪音，运行更稳定。

Gearbox——Maintenance-free, working-level for M6. BMS european electric chain with a rated service life of 1900 full load hours. In practical terms, this means the service life is extended by approx. 20%. the helical gearing inside the gearbox also reduces operating noise and provide smooth operation.

2

制动器——免维护，由于磨损小，无需调节；制动快速平稳。制动器外壳采用双重密封，可在恶劣气候或工作环境下工作。

Brake——Maintenance-free, because of minimum wear, adjustment is not necessary. The brake is enclosed in enclosed in the electrical panel and provides double protection from the elements

3

摩擦离合器——免维护。摩擦离合器集成在制动器的后端，能有效起到过载保护作用。内部具有速度检测器，非正常情况下可有效保障葫芦链条绝不会下滑。

Slip clutch——Maintenance-free. Integrated behind the brake in the power drive, it provides reliable protection against overload. Integrated slip clutch monitoring prevents permanent damage to the slip clutch.

4

手电门的高度调节——在吊钩行程2—5m和5—8m的范围内，控制电缆长度和手电门悬挂高度可无限变化。多余的控制电缆可被容纳在统一维修区。

Height adjustable control pendant cable——The length of the control cable. Therefore, the suspension height of the control pendant can be infinitely varied for a hook path range of 2—5m and 5—8m. The excess control cable is accommodated behind the service cover.



5

控制方式——24V低压控制方式，上下限位开关。

Control——24V contactor control, operating limit switches (upper/lower).

6

链条——高强度、抗老化的远泰专用链条，表面经过硬化处理。镀锌和额外的表面处理保护其不受恶劣环境的侵蚀。

Steel chain——A special chain of high-strength, hardened age-resistant material. Galvanized and other surface treatments are available to protect against specific hostile environments.

7

悬挂装置——BMS型欧式电动环链葫芦采用紧凑的C型结构尺寸，可充分利用高度空间。BMS型欧式电动环链葫芦配有多款悬挂装置，使其连接更为完美。

Suspension bracket——BMS hoists are supplied with short and long suspension brackets as standard and can always be attached to the super-structure with the optimal connectin.

8

外壳——坚固，重量轻的压铸铝外壳，紧凑、现代化的工业设计。汽车级油漆，提供保护更长久。

Housing——Robust and lightweight die-cast aluminium housing of compact and modern industrial design. Automotive paint, to provide more long-term protection.

9

葫芦电机——坚固持久的高性能电机，即使在高温和长期运行中，也具有大的安全储备。采用两级起升速度，另有变频控制，提供多速度变化。

Hoist motor——High-performance motor with large safety reserves even at high ambient temperatures and in prolonged operation. Using 2 hoist speed with 1:4 speed ratio and frequency Control to multi-speed requirements.

10

链轮——插入式连接便于快速更换整个链轮而无需拆卸电机或齿轮部件，从而大大减少了停机时间。采用高度耐磨的材料，使用寿命长。

Chain guide——The unit is a complete assembly consisting of the chain and chain guide which facilitates quick and easy replacement of the entire chain drive without having to remove the motor or gear parts. Downtime can therefore be reduced significantly. The chain drive consists of highly wear-resistant materials for long service life.

11

集链盒——采用坚固、有韧性并且耐冲击的特殊塑料；可放置长度8米的链条，也可提供可放置链条长达40米或120米的集链盒。

Chain collector box——Suspended from a pivoting connection, is made of tough, flexible and particularly impact-resistant plastic; capacity for up to 8m hook path, A flexible chain container for chain lengths up to 40m as well as special lengths up to 120m.

12

吊钩组——吊钩装置手握舒适，符合人体工程学原理。吊钩经锻造加工，强度绝佳，吊钩360度旋转，特殊设计的安全舌片，确保操作安全。

Bottom block——Comfortable hook device by hand For improved ergonomic handling of the hook. The hook after forging processing to make great-strength, hooks rotate by 360 degrees, a specially designed safety tongue, to ensure safe operation.

EUROPEAN ELECTRIC CHAIN HOIST WITH HOOK TYPE

欧式电动环链葫芦（固定式）



基本特征

BMS系列欧式电动环链葫芦可方便的安装到KBK标准组件的轨道上。

Basic characteristics

BMS european electric chain hoist can be installed to the KBK orbit of standard components

测试简单

所有电器连接均为插入式——即插即用通用型悬挂机构，既能用于KBK标准轨道又可与小车快速链接。

Easy test

All electrical connection to plug in, plug and play universal suspension mechanism,both can used for KBK standard track and can be connected to trolley quickly

人性化设计

控制电缆长度可以调节，手电门总在最合适的位置。手电门人性化设计，握感舒适，免除操作疲劳。

Humanized design

Control cable length can be adjusted,control pendant always in the most appropriate location. Control pendant is humanized design,grip feels comfortable,avoid operation fatigue

统一维修检测后盖

可用于电器接插，手电门高度调节，链条润滑。无需拆卸其他部件，快速更换起重链轮，减少停机时间。

Unified maintenance test back cover

Can be used for electric plug,Control pendant can be high adjusted, the chain lubrication,without having to remove other components, fastly replace chain guide,and reduce downtime

标准双速电机，工作效率更高

低压24V控制更安全。

Standard double speed motor,higher working efficiency

24V control voldage is more safe

Technical Parameters

技术参数

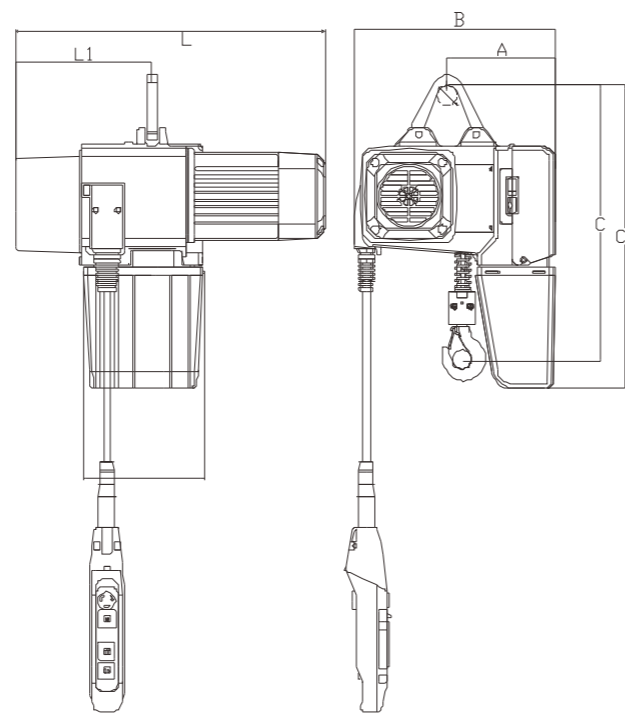

型号 Model	载重量 (KG)	起升速度 (m/min)	电机功率 (Kw)	电机转速 (r/min)	工作电压 (V)	控制电压 (V)	工作级别 (FEM/ISO)
BMS0.125-01M	125	8/2	0.4/0.1	2880/720	220-460	24	2M/M5
BMS0.125-01M	125	13/3.2	0.75/0.2	2880/720	220-460	24	2M/M5
BMS0.25-01M	250	8/2	0.4/0.1	2880/720	220-460	24	2M/M5
BMS0.5-01M	500	8/2	0.75/0.2	2880/720	220-460	24	2M/M5
BMS0.5-02M	500	4/1	0.4/0.1	2880/720	220-460	24	2M/M5
BMS01-01M	1000	8/2	1.5/0.37	2880/720	220-460	24	2M/M5
BMS01-02M	1000	4/1	0.75/0.2	2880/720	220-460	24	2M/M5
BMS02-02M	2000	4/1	1.5/0.37	2880/720	220-460	24	2M/M5

型号 Model	L	L1	A	B	C	C1
BMS0.125-01M	440	194	160	288	400	425
BMS0.125-01M	464	197	170	315	420	450
BMS0.25-01M	440	194	160	288	400	425
BMS0.5-01M	464	197	170	315	420	450
BMS0.5-02M	440	194	160	288	470	425
BMS01-01M	548	260	182	343	560	640
BMS01-02M	464	197	170	315	490	450
BMS02-02M	548	260	182	343	630	640

EUROPEAN ELECTRIC CHAIN HOIST WITH MANUAL TROLLEY

欧式电动环链葫芦 (配手动跑车)



基本特征

BMS系列欧式电动环链葫芦可方便的安装到KBK标准组件的轨道上。

Basic characteristics

BMS european electric chain hoist can be installed to the KBK orbit of standard components

测试简单

所有电器连接均为插入式——即插即用通用型悬挂机构,既能用于KBK标准轨道又可与小车快速链接。

Easy test

All electrical connection to plug in, plug and play universal suspension mechanism,both can used for KBK standard track and can be connected to trolley quickly

人性化设计

控制电缆长度可以调节,手电门总在最合适的位置。手电门人性化设计,握感舒适,免除操作疲劳。

Humanized design

Control cable length can be adjusted,control pendant always in the most appropriate location. Control pendant is humanized design,grip feels comfortable,avoid operation fatigue

统一维修检测后盖

可用于电器接插,手电门高度调节,链条润滑。无需拆卸其他部件,快速更换起重链轮,减少停机时间。

Unified maintenance test back cover

Can be used for electric plug,Control pendant can be high adjusted, the chain lubrication,without having to remove other components, fastly replace chain guide,and reduce downtime

标准双速电机,工作效率更高

低压24V控制更安全。

Standard double speed motor,higher working efficiency

24V control voldage is more safe

Technical Parameters

技术参数

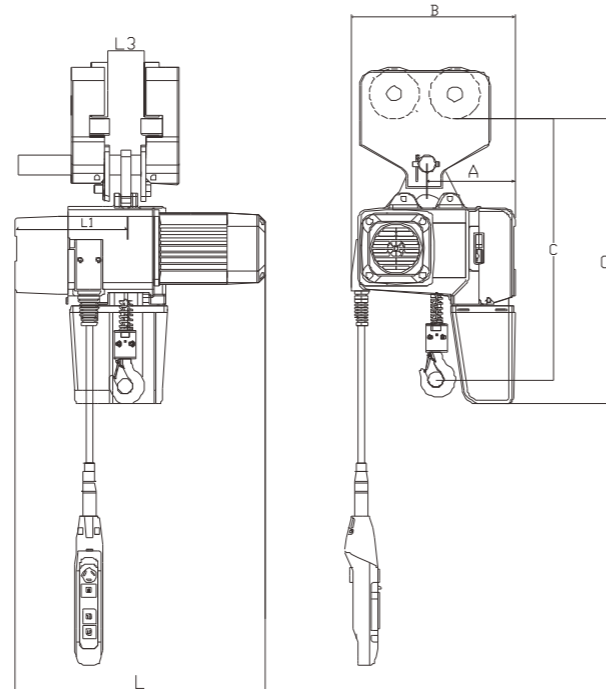

型号 Model	载重量 (KG)	起升速度 (m/min)	电机功率 (Kw)	电机转速 (r/min)	工作电压 (V)	控制电压 (V)	工作级别 (FEM/ISO)
BMS0.125-01M	125	8/2	0.4/0.1	2880/720	220-460	24	2M/M5
BMS0.125-01M	125	13/3.2	0.75/0.2	2880/720	220-460	24	2M/M5
BMS0.25-01M	250	8/2	0.4/0.1	2880/720	220-460	24	2M/M5
BMS0.5-01M	500	8/2	0.75/0.2	2880/720	220-460	24	2M/M5
BMS0.5-02M	500	4/1	0.4/0.1	2880/720	220-460	24	2M/M5
BMS01-01M	1000	8/2	1.5/0.37	2880/720	220-460	24	2M/M5
BMS01-02M	1000	4/1	0.75/0.2	2880/720	220-460	24	2M/M5
BMS02-02M	2000	4/1	1.5/0.37	2880/720	220-460	24	2M/M5

型号 Model	L	L1	L3	A	B	C	C1
BMS0.125-01M	440	194	100-200	160	288	470	470
BMS0.125-01M	464	197	100-200	170	315	490	495
BMS0.25-01M	440	194	100-200	160	288	470	470
BMS0.5-01M	464	197	100-200	170	315	490	495
BMS0.5-02M	440	194	100-200	160	288	540	470
BMS01-01M	548	260	100-200	182	343	600	680
BMS01-02M	464	197	100-200	170	315	560	495
BMS02-02M	548	260	100-200	182	343	670	690

EUROPEAN ELECTRIC CHAIN HOIST WITH ELECTRIC TROLLEY

欧式电动环链葫芦 (配电动跑车)



基本特征

BMS系列欧式电动环链葫芦可方便的安装到KBK标准组件的轨道上。

Basic characteristics

BMS european electric chain hoist can be installed to the KBK orbit of standard components

测试简单

所有电器连接均为插入式——即插即用通用型悬挂机构,既能用于KBK标准轨道又可与小车快速链接。

Easy test

All electrical connection to plug in, plug and play universal suspension mechanism,both can used for KBK standard track and can be connected to trolley quickly

人性化设计

控制电缆长度可以调节,手电门总在最合适的位置。手电门人性化设计,握感舒适,免除操作疲劳。

Humanized design

Control cable length can be adjusted,control pendant always in the most appropriate location. Control pendant is humanized design,grip feels comfortable,avoid operation fatigue

统一维修检测后盖

可用于电器接插,手电门高度调节,链条润滑。无需拆卸其他部件,快速更换起重链轮,减少停机时间。

Unified maintenance test back cover

Can be used for electric plug,Control pendant can be high adjusted, the chain lubrication,without having to remove other components, fastly replace chain guide,and reduce downtime

标准双速电机,工作效率更高

低压24V控制更安全。

Standard double speed motor,higher working efficiency

24V control voldage is more safe

Technical Parameters

技术参数

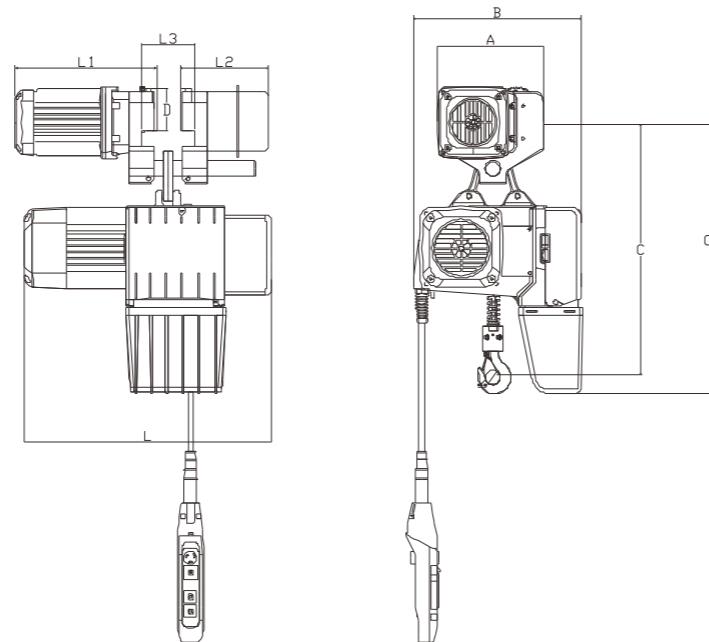

型号 Model	载重量 (KG)	起升速度 (m/min)	电机功率 (Kw)	电机转速 (r/min)	工作电压 (V)	控制电压 (V)	工作级别 (FEM/ISO)
BMS0.125-01M	125	8/2	0.4/0.1	2880/720	220-460	24	2M/M5
BMS0.125-01M	125	13/3.2	0.75/0.2	2880/720	220-460	24	2M/M5
BMS0.25-01M	250	8/2	0.4/0.1	2880/720	220-460	24	2M/M5
BMS0.5-01M	500	8/2	0.75/0.2	2880/720	220-460	24	2M/M5
BMS0.5-02M	500	4/1	0.4/0.1	2880/720	220-460	24	2M/M5
BMS01-01M	1000	8/2	1.5/0.37	2880/720	220-460	24	2M/M5
BMS01-02M	1000	4/1	0.75/0.2	2880/720	220-460	24	2M/M5
BMS02-02M	2000	4/1	1.5/0.37	2880/720	220-460	24	2M/M5

型号 Model	L	L1	L2	L3	A	B	C	C1
BMS0.125-01M	440	260	164	100-200	201	288	470	470
BMS0.125-01M	464	260	164	100-200	201	315	490	495
BMS0.25-01M	440	260	164	100-200	201	288	470	470
BMS0.5-01M	464	260	164	100-200	201	315	490	495
BMS0.5-02M	440	260	164	100-200	201	288	540	470
BMS01-01M	548	305	190	100-200	340	343	600	680
BMS01-02M	464	260	164	100-200	315	315	560	495
BMS02-02M	548	290	200	100-200	340	343	670	690

EUROPEAN LOW HEADROOM TYPE ELECTRIC CHAIN HOIST

欧式电动环链葫芦 (低净空式)

基本特征

BMS系列欧式电动环链葫芦可方便的安装到KBK标准组件的轨道上。

Basic characteristics

BMS european electric chain hoist can be installed to the KBK orbit of standard components

测试简单

所有电器连接均为插入式——即插即用通用型悬挂机构,既能用于KBK标准轨道又可与小车快速链接。

Easy test

All electrical connection to plug in, plug and play universal suspension mechanism,both can used for KBK standard track and can be connected to trolley quickly

人性化设计

控制电缆长度可以调节,手电门总在最合适的位置。手电门人性化设计,握感舒适,免除操作疲劳。

Humanized design

Control cable length can be adjusted,control pendant always in the most appropriate location. Control pendant is humanized design,grip feels comfortable,avoid operation fatigue

统一维修检测后盖

可用于电器接插,手电门高度调节,链条润滑。无需拆卸其他部件,快速更换起重链轮,减少停机时间。

Unified maintenance test back cover

Can be used for electric plug,Control pendant can be high adjusted, the chain lubrication,without having to remove other components, fastly replace chain guide,and reduce downtime

标准双速电机,工作效率更高

低压24V控制更安全。

Standard double speed motor,higher working efficiency

24V control voldage is more safe



Technical Parameters

技术参数

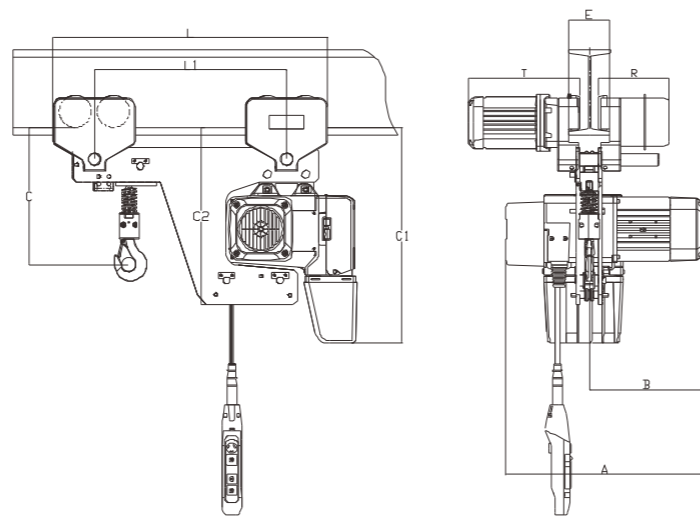

型号 Model	载重量 (KG)	起升速度 (m/min)	电机功率 (Kw)	电机转速 (r/min)	工作电压 (V)	控制电压 (V)	工作级别 (FEM/ISO)
BMS0.125-01M	125	8/2	0.75/0.2	2880/720	220-460	24	2M/M5
BMS0.125-01M	125	13/3.2	0.75/0.2	2880/720	220-460	24	2M/M5
BMS0.25-01M	250	8/2	0.75/0.2	2880/720	220-460	24	2M/M5
BMS0.5-01M	500	8/2	0.75/0.2	2880/720	220-460	24	2M/M5
BMS0.5-02M	500	4/1	0.75/0.2	2880/720	220-460	24	2M/M5
BMS01-02M	1000	4/1	0.75/0.2	2880/720	220-460	24	2M/M5

型号 Model	L	L1	C	C1	C2	A	B	T	E	R
BMS0.125-01M	645	454	330	510	415	464	267	260	100-200	164
BMS0.125-01M	645	454	330	510	415	464	267	260	100-200	164
BMS0.25-01M	645	454	330	510	415	464	267	260	100-200	164
BMS0.5-01M	645	454	330	510	415	464	267	260	100-200	164
BMS0.5-02M	645	454	410	510	415	464	267	260	100-200	164
BMS01-02M	645	454	410	510	415	464	267	260	100-200	164

EUROPEAN ELECTRIC CHAIN HOIST (DOUBLE HOOK)

欧式电动环链葫芦 (双钩)

基本特征

BMS系列欧式电动环链葫芦可方便的安装到KBK标准组件的轨道上。

Basic characteristics

BMS european electric chain hoist can be installed to the KBK orbit of standard components

测试简单

所有电器连接均为插入式——即插即用通用型悬挂机构,既能用于KBK标准轨道又可与小车快速链接。

Easy test

All electrical connection to plug in, plug and play universal suspension mechanism,both can used for KBK standard track and can be connected to trolley quickly

人性化设计

控制电缆长度可以调节,手电门总在最合适的位置。手电门人性化设计,握感舒适,免除操作疲劳。

Humanized design

Control cable length can be adjusted,control pendant always in the most appropriate location. Control pendant is humanized design,grip feels comfortable,avoid operation fatigue

统一维修检测后盖

可用于电器接插,手电门高度调节,链条润滑。无需拆卸其他部件,快速更换起重链轮,减少停机时间。

Unified maintenance test back cover

Can be used for electric plug,Control pendant can be high adjusted, the chain lubrication,without having to remove other components, fastly replace chain guide,and reduce downtime

标准双速电机,工作效率更高

低压24V控制更安全。

Standard double speed motor,higher working efficiency

24V control voldage is more safe

Technical Parameters

技术参数

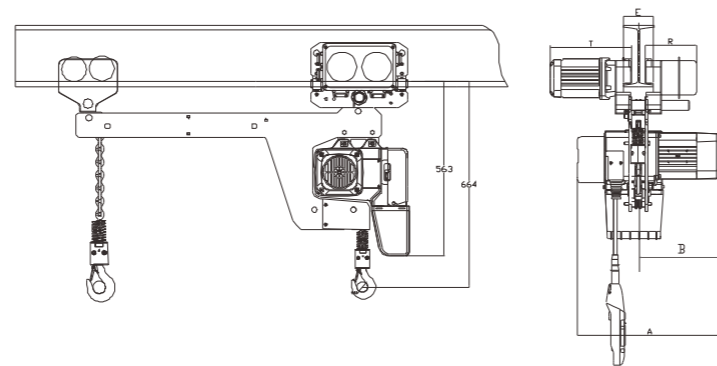

型号 Model	载重量 (KG)	起升速度 (m/min)	电机功率 (Kw)	电机转速 (r/min)	工作电压 (V)	控制电压 (V)	工作级别 (FEM/ISO)
BMS0.125-01M	125	8/2	0.75/0.2	2880/720	220-460	24	2M/M5
BMS0.25-01M	250	8/2	0.75/0.2	2880/720	220-460	24	2M/M5
BMS0.5-01M	500	8/2	0.75/0.2	2880/720	220-460	24	2M/M5
BMS0.5-02M	500	4/1	0.75/0.2	2880/720	220-460	24	2M/M5
BMS01-02M	1000	4/1	0.75/0.2	2880/720	220-460	24	2M/M5

型号 Model	A	B	T	E	R
BMS0.125-01M	464	267	260	100-200	164
BMS0.25-01M	464	267	260	100-200	164
BMS0.5-01M	464	267	260	100-200	164
BMS0.5-02M	464	267	260	100-200	164
BMS01-02M	464	267	260	100-200	164