



# Motorized Trolley & Manual Trolley for Electric Chain Hoist



# 300Kg-10Ton

## Motorized Trolley

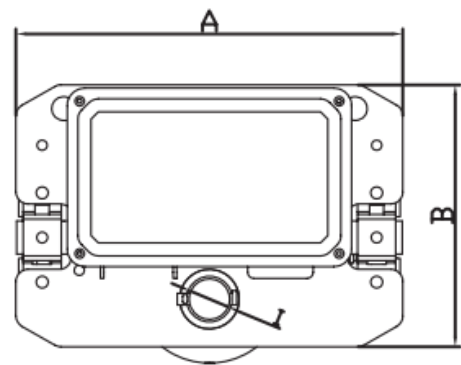
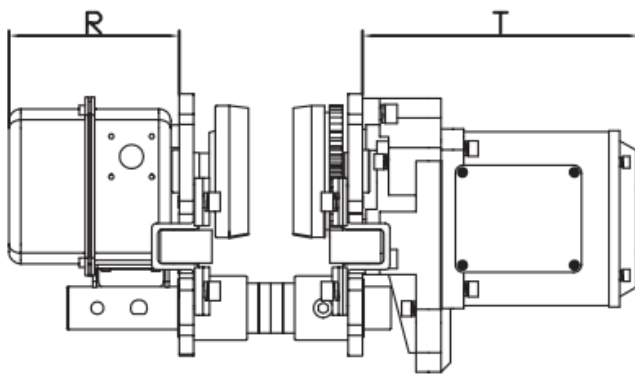

Type	ET-003	ET-005	ET-010	ET-020	ET-030	ET-050	ET-075	ET-100	
Capacity(t)	0.3	0.5	1	2	3	5	7.5	10	
Unit(mm)	A	315	315	315	325	340	400	400	500
	B	212	212	212	220	250	291	291	370
	R	120	142	142	142	142	142	142	142
	T	142	231	231	231	231	231	231	231
	I	φ28	φ31	φ31	φ36	φ43	φ54	φ54	φ70
Speed(m/min)	12.2	11/21	11/21	11/21	11/21	11/21	11/21	11/21	
Motor(Kw)	0.21	0.4	0.4	0.4	0.75	0.75	0.75	0.75	
Minimum Turning Radius(m)	0.8	0.8	0.8	0.8	1.0	1.8	1.8	2.5	
I-Beam(mm)	60-190	60-190	60-190	82-228	82-228	100-256	100-256	120-294	

# 300Kg-5Ton

## Manual Trolley

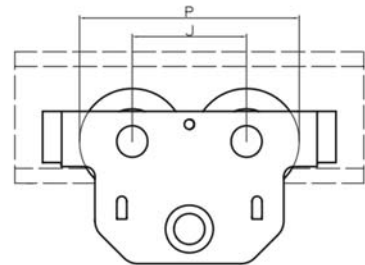
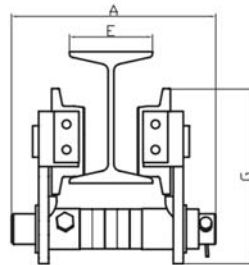

Type		MT-003	MT-005	MT-010	MT-020	MT-030	MT-050
Capacity(t)		0.3	0.5	1	2	3	5
Unit(mm)	A	460	200	200	218	275	275
	G	180	170	170	205	236	280
	J	91	115	115	138	157	178
	E	52-100	52-120	52-120	60-105	60-105	80-180
	P	163	221	221	265	305	332
Minimum Turning Radius(m)		0.6	0.6	0.6	1.0	1.0	1.2



## Yuantai Crane Machinery

Crane&Hoist Solution Supplier

### Address

3#-A-2005, Shenglong Plaza, Zhengzhou City, Henan Province, China.

### Tel/Whatsapp/Wechat:

008613653868275

### Fax

0086-371-65760775

### Email

[jason@ytcrane.com](mailto:jason@ytcrane.com)

### Website

[www.ythoist.com](http://www.ythoist.com)

