



Low Headroom type Electric Chain Hoist

Yuantai Low Headroom Electric Chain Hoists are designed for those applications where space is limited.

Lifting capacity: 0.5-10 tons.

Power supply: 220-550V 50/60Hz, 5t and below can be single-phase power.



Products Code

WBH / HHBB - 010 01 S E

Products Series

Lifting Capacity	
Code	Load(t)
001	0.1
002	0.2
003	0.3
004	0.4
005	0.5
010	1.0
015	1.5
020	2.0
025	2.5
030	3.0
050	5.0
075	7.5
100	10
150	15
200	20
300	30
350	35

Falls	
Code	Falls
01	1
02	2
03	3
04	4
06	6
08	8
10	10
12	12
16	16

Speed Type
 S. Single Speed
 D. Dual Speed

Hoist Type
 F. Hook type
 M. Manual trolley type
 E. Motorized trolley type
 L. Low headroom type

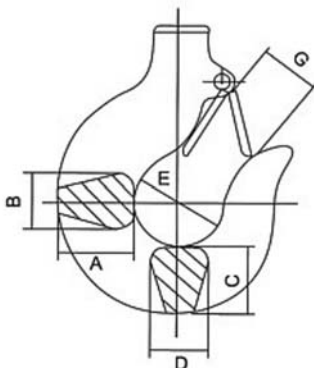

Type	Load(t)	T	B	A	B	C	D	E	G
WBH / HHBB	0.2, 0.3, 0.5	T	B	27	18	25	17	35	28
	1	T	B	34	24	30	24	42	32
	2	T	B	46	29	39	30	49	40
	3	T	B	56	35	49	34	59	48
	5	T	B	67	43	57	44	60	48
	7.5	T	B	82	55	80	48	85	80
	10	T	B	82	55	80	48	85	80
	15	T	B	110	78	120	80	120	96
	20, 25	T	B	142	95	155	98	150	115
	30	T	B	160	130	150	130	140	95
	35	T	B	195	150	160	150	160	110

T-top hook / B-load hook

500Kg-10Ton

Single Speed Low Headroom type Electric Chain Hoist



Type	Capacity (t)	Lifting Speed (m/min)	Lifting Motor			Chain Falls	Chain Spec	I-Beam (mm)	Weight Added with 1m Higher
			Power	Rotation Speed (r/min)	Power Supply				
WBH-00501SL	0.5	6.8	0.75	1440	200-460V 1/3 Phase 50/60Hz	1	φ6.3	60-190	0.81
WBH-01001SL	1	6.6	1.5	1440		1	φ7.1	60-190	1.1
WBH-01501SL	1.5	8.8	3.0	1440		1	φ10.0	82-228	2.3
WBH-02001SL	2	6.6	3.0	1440		1	φ10.0	82-228	2.3
WBH-02002SL	2	3.3	1.5	1440		2	φ7.1	82-228	2.2
WBH-02501SL	2.5	5.4	3.0	1440		1	φ11.2	82-228	2.8
WBH-03001SL	3	5.4	3.0	1440		1	φ11.2	82-228	2.8
WBH-03002SL	3	4.4	3.0	1440		2	φ10.0	82-228	4.7
WBH-05002SL	5	2.7	3.0	1440		2	φ11.2	100-256	5.6
WBH-07503SL	7.5	1.8	3.0	1440		3	φ11.2	100-256	8.4
WBH-10004SL	10	2.7	3.0*2	1440	3 Phase 50/60Hz	4	φ11.2	120-294	11

500Kg-10Ton

Double Speed Low Headroom type Electric Chain Hoist



Type	Capacity (t)	Lifting Speed (m/min)	Lifting Motor			Chain Falls	Chain Spec	I-Beam (Kg)	Weight Added with 1m Higher
			Power	Rotation Speed (r/min)	Power Supply				
WBH-00501DL	0.5	6.9/2.3	0.8/0.27	2890/980	200-460V 1/3 Phase 50/60Hz	1	φ 6.3	60-190	0.81
WBH-01001DL	1	6.9/2.3	1.8/0.6			1	φ 7.1	60-190	1.1
WBH-01501DL	1.5	9.0/3.0	3.0/1.0			1	φ 10.0	82-228	2.3
WBH-02001DL	2	6.9/2.3	3.0/1.0			1	φ 10.0	82-228	2.3
WBH-02002DL	2	3.4/1.1	1.8/0.6			2	φ 7.1	82-228	2.2
WBH-02501DL	2.5	5.4/1.8	3.0/1.0			1	φ 11.2	82-228	2.8
WBH-03001DL	3	5.4/1.8	3.0/1.0			1	φ 11.2	82-228	2.8
WBH-03002DL	3	4.5/1.5	3.0/1.0			2	φ 10.0	82-228	4.7
WBH-05002DL	5	2.7/0.9	3.0/1.0			2	φ 11.2	100-256	5.6
WBH-07503DL	7.5	1.8/0.6	3.0/1.0			3	φ 11.2	100-256	8.4
WBH-10004SE	10	2.7/0.9	3.0*2/1.0*2	4	φ 11.2	120-294	11		

300Kg-5Ton

Motorized Trolley

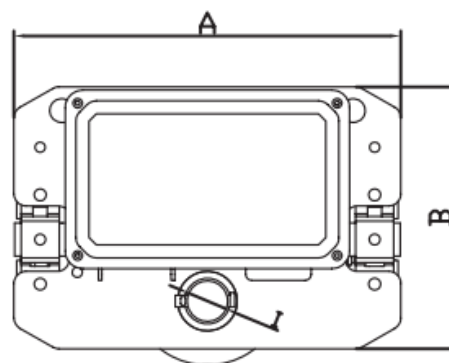
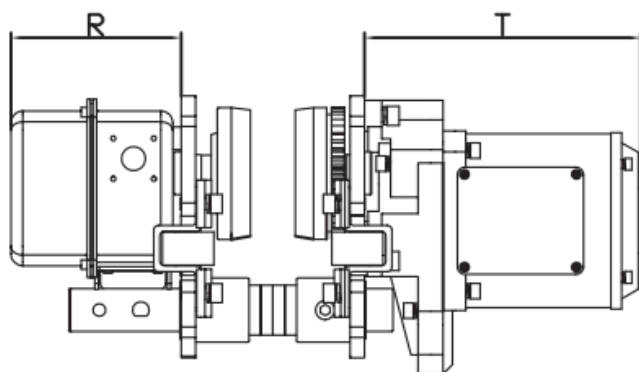

Type	ET-003	ET-005	ET-010	ET-020	ET-030	ET-050	ET-075	ET-100
Capacity(t)	0.3	0.5	1	2	3	5	7.5	10
Unit(mm)	A	315	315	315	325	340	400	500
	B	212	212	212	220	250	291	370
	R	120	142	142	142	142	142	142
	T	142	231	231	231	231	231	231
	I	φ28	φ31	φ31	φ36	φ43	φ54	φ54
Speed(m/min)	12.2	11/21	11/21	11/21	11/21	11/21	11/21	11/21
Motor(Kw)	0.21	0.4	0.4	0.4	0.75	0.75	0.75	0.75
Minimum Turning Radius(m)	0.8	0.8	0.8	0.8	1.0	1.8	1.8	2.5
I-Beam(mm)	60-190	60-190	60-190	82-228	82-228	100-256	100-256	120-294



Yuantai Crane Machinery

Crane&Hoist Solution Supplier

Address

3#-A-2005, Shenglong Plaza, Zhengzhou City, Henan Province, China.

Tel/Whatsapp/Wechat:

008613653868275

Fax

0086-371-65760775

Email

jason@ytcrane.com

Website

www.ythoist.com