

Stage Chain Hoist

YUANTAI CRANE

YT-HGA D8 CLASSICAL MODEL

ADVANTAGE

BGV-D8 Standard and approved by CE / TUV Certificates.

Inside safe mechanical Brake Clutch

Wi compact upper limiter is available

Special alloy steel Load chain sprocket

New design side-out chain structure prevents stuck.

Mechanical brake and electromagnetic brake

EN 818-7 standard G80 chain

Aluminum alloy stretching shell with unique cooling function

High-strength aluminum alloy Gear Box

www.ythoist.com

jason@ytc Crane.com



YT-HGA8 D8

220V-440V 3 Phase

Leading the entertainment industry for more than one decade, Yuantai Crane offers best-in-class performance, safety and reliability. The YT Hoist is universally trusted by rigging professionals around the world and is ideal for touring concerts and productions both indoors and outside.

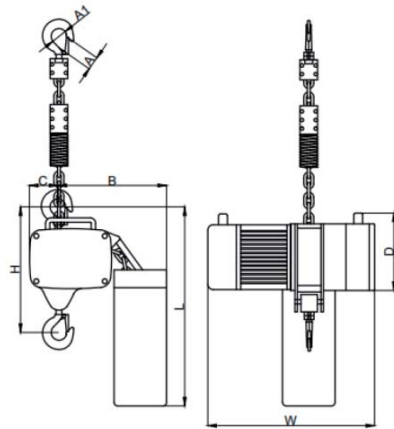

Specifications	
SWL acc. DGUV V54 (D8)	500Kg/1000Kg/2000Kg
Power supply	220-440V 3Phase 50/60Hz
Cable	1m Cable with CEE-16/4
Chain	EN818-7
Dynamic safety factor for chain	min. 8:1
Grade of steel	80
Chain surface	galvanized
Chain Guide	Precise chain guide with 5-pocket chain wheel
Clutch	Patented friction clutch for overload protection
Full load noise level(db)	≤65
Brake	Paramagnetic brakex1
Load hook	1-fall / tumble
Suspension	suspension hook
Mounting position	climbing & stationary
Plastic handles	without
Protection level	IP 55
Mechanism class /FEM9.511	1Bm/ 25% ED
Color	black, RAL9005 matt

Capacity	Chain Fall	Speed (m/min)	Power (kw)	Chain (mm)	Hoist Dimension(mm)						No Chain Self Weight (kg)	Chain Weight (Kg/m)	Flight Case	
					L	W	H	D	A	A1			Weight(Kg)	Size(mm)
HGA8-500KG	1	4	0.75	6.3*19	480	410	530	200	23	32	27	0.86	19.5	580*390*490
HGA8-1000KG	1	4	1.5	7.1*21	960	470	650	240	26	38	37.5	1.1	20	600*450*500
HGA8-2000KG	1	4	3.0	10*30	1200	630	800	280	33	47	76	2.0	21	680*450*650
HGA8-2000KG	2	2	1.5	7.1*21	960	470	750	240	32	47	37.5	2.2	19.5	680*450*650

YT-HGA9 D8

220V-440V 3 Phase

Leading the entertainment industry for more than one decade, Yuantai Crane offers best-in-class performance, safety and reliability. The YT Hoist is universally trusted by rigging professionals around the world and is ideal for touring concerts and productions both indoors and outside.

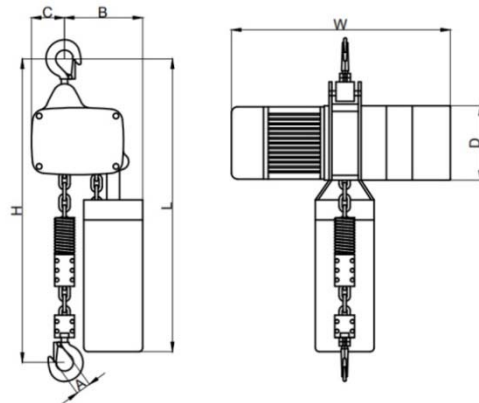

Specifications	
SWL acc. DGUV V54 (D8)	500Kg/1000Kg/2000Kg
Power supply	220-440V 1/3Phase 50/60Hz
Cable	1m Cable with CEE-16/4
Chain	EN818-7
Dynamic safety factor for chain	min. 8:1
Grade of steel	80
Chain surface	galvanized
Chain Guide	Precise chain guide with 5-pocket chain wheel
Clutch	Patented friction clutch for overload protection
Full load noise level(db)	≤65
Brake	Paramagnetic brakex1
Load hook	1-fall / tumble
Suspension	suspension hook
Mounting position	climbing & stationary
Plastic handles	without
Protection level	IP 55
Mechanism class /FEM9.511	1Bm/ 25% ED
Color	black, RAL9005 matt

Capacity	Chain Fall	Speed (m/min)	Power (kw)	Chain (mm)	Hoist Dimension(mm)						No Chain Self Weight (kg)	Chain Weight (Kg/m)	Flight Case	
					L	W	H	D	A	A1			Weight(Kg)	Size(mm)
HGA9-500KG	1	6.8	0.75	6.3*19	560	490	400	160	24	33	30	0.79	19.5	540*325*450
HGA9-1000KG	1	7/5	1.5	7.1*21	800	560	520	240	26	43	41	1.1	20	595*430*460
HGA9-2000KG	1	6	3.0	10*30	920	630	720	300	32	47	80	2.1	21	690*400*590



Yuantai Crane Machinery

Crane&Hoist Solution Supplier

Address

3#-A-2005, Shenglong Plaza, Zhengzhou City, Henan
Province, China.

Tel/Whatsapp/Wechat:

008613653868275

Fax

0086-371-65760775

Email

jason@ytcrane.com

Website

www.ythoist.com